Parts list



Mounted Reversible Ploughs

PUSHPAK OPAL 90

Ref. No.: 175 1842

1/09.04

Deccan Farm Equipment Pvt. Ltd
(Manufactures of Agrucultural Equipments)
C-35-, M.I.D.C. , Shirolī,
Kolhapur -416 112 ,
Maharashtra (India)

Phone : +91-230-2468904 Fax : +91-230-2469002

Contents

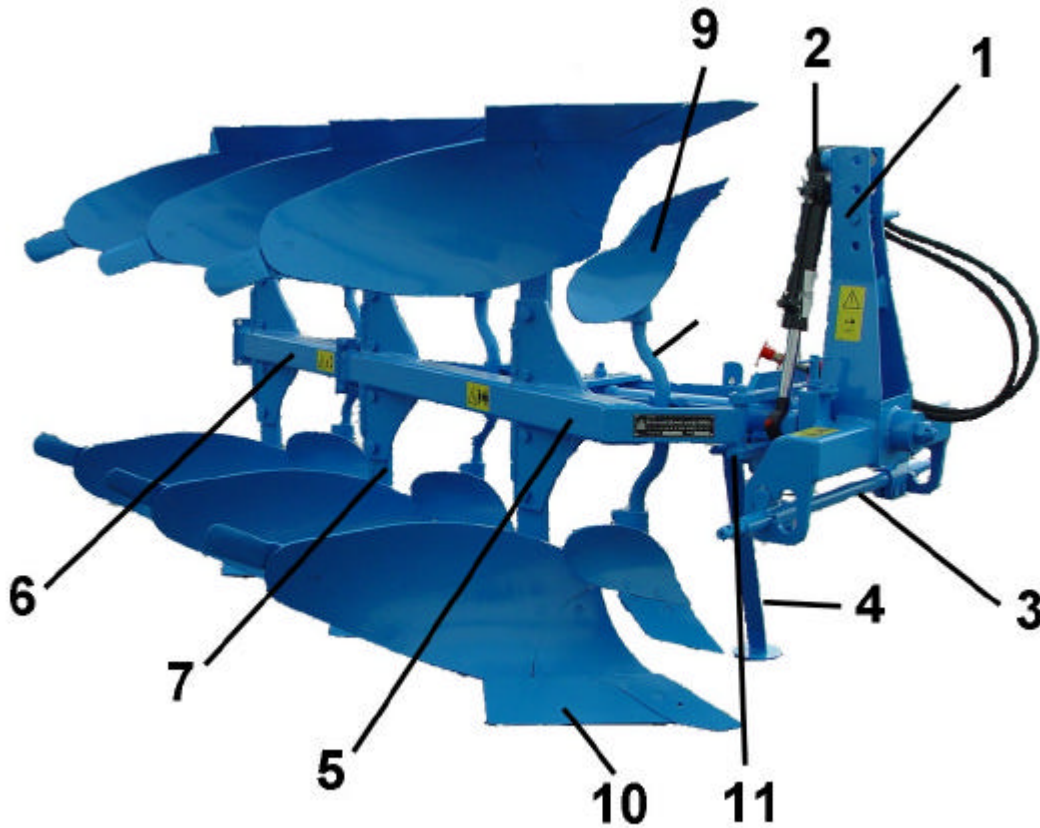
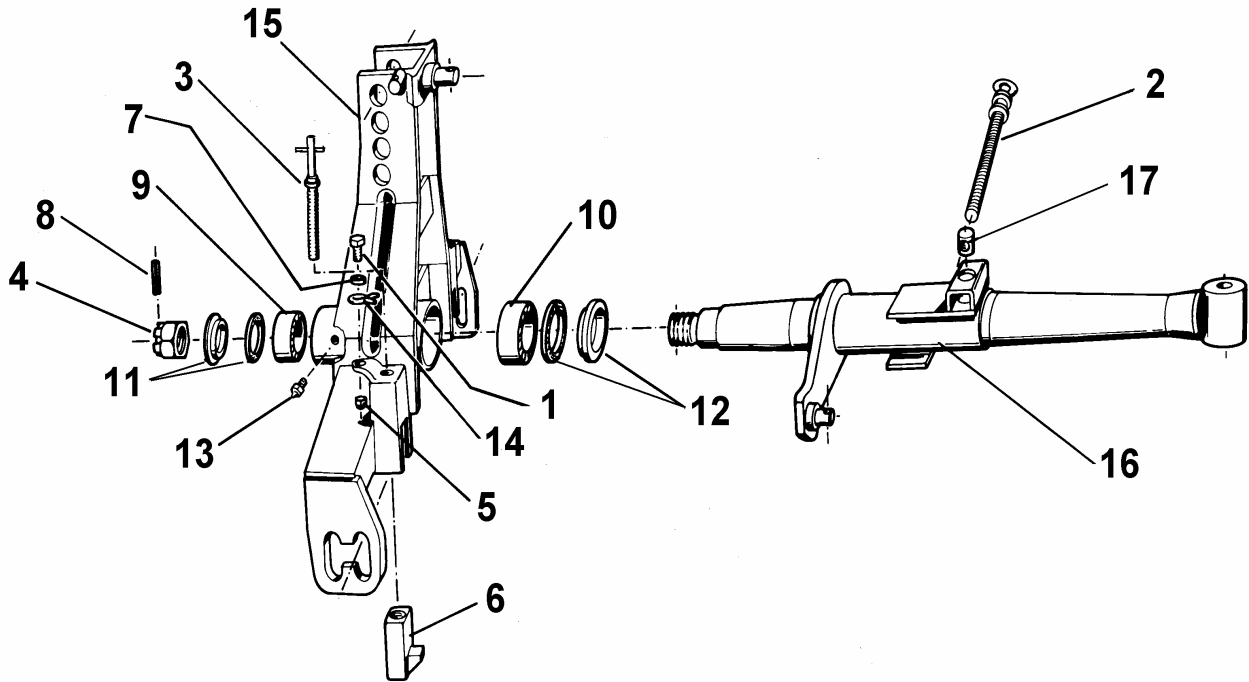

Table 1	Turnover device
Table 2	Turnover ram with hoses
Table 3	Drawbar and top link pin
Table 4	Stand
Table 5	Basic frame
Table 6	Frame extension
Table 7	Legs and bolts
Table 8	Skim stalk
Table 9	Skimmer No. 1
Table 10	Universal body No. 35
Table 11	Adjuster screw complete

Table 1

Turnover device



Pos. No.	Description	Reference
1	Bolt	P301 7280
2	Adjuster screw, complete	P302 7890.0
3	Adjuster screw	P302 0384.0
4	Castle nut	P303 0141
5	Selflocking nut	P303 0932
6	Stop	P433 9188
7	Washer	P305 8694
8	Expansion pin	P309 6053
9	Bearing	P319 9131
10	Bearing	P319 9215
11	Seal complete	P323 0010.0
12	Seal complete	P323 0015.0
13	Grease nipple	P323 6348
14	Clip	P329 8616
15	Headstock	P433 7438
16	Turnover axle	P433 8286
17	Nut of adjuster screw	P303 2688

Table 2

Turnover ram with hoses

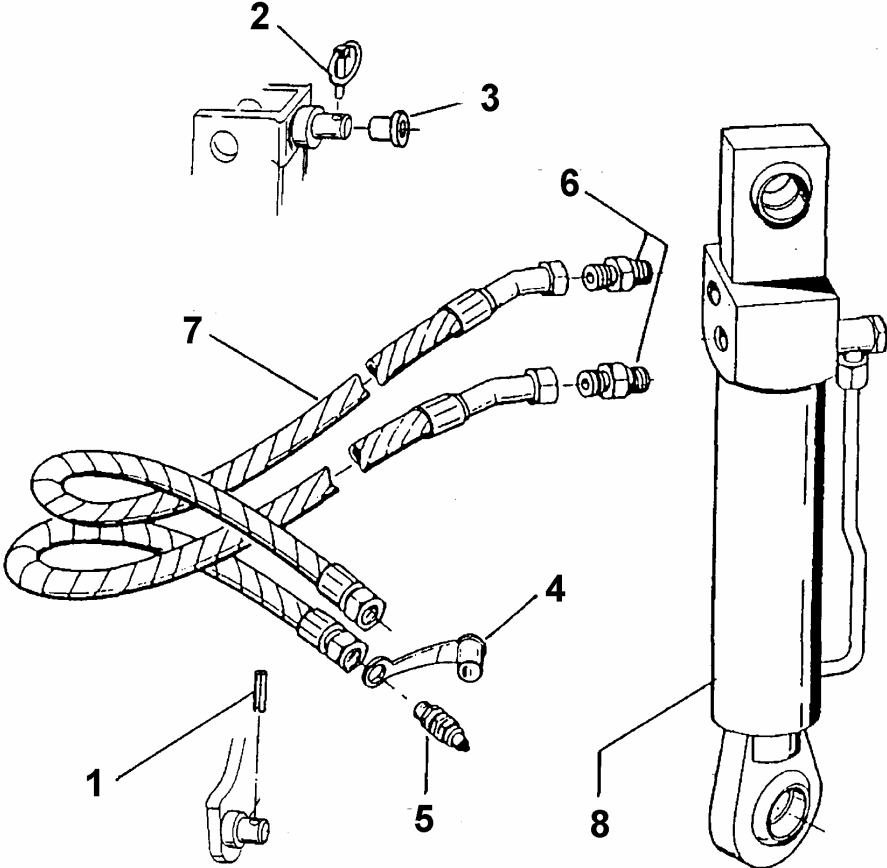

Pos. No.	Description	Reference
1	Expansion pin	P309 6072
2	Lynch pin	P311 9300
3	Bush with collar	P317 9360
4	Cap	P375 2166
5	Coupling	P375 2718
6	Nipple	P375 4020
7	Hydraulic hose	P475 2617
8	Turnover ram	P575 2388

Table 3

Drawbar and top link pin

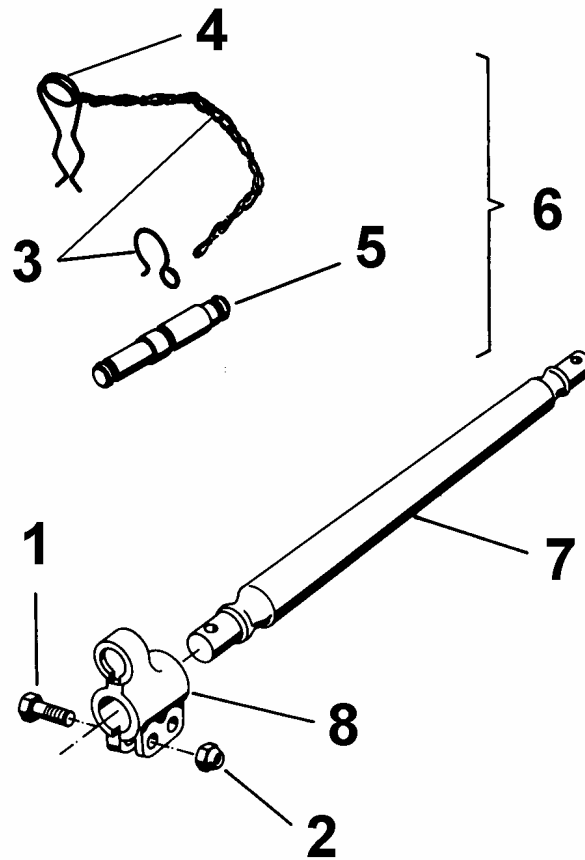

Pos. No.	Description	Reference
1	Bolt	P301 3867
2	Selflocking nut	P303 0935
3	Clip with chain	P305 8560
4	Securing clip	P311 8610
5	Top link pin Cat. I and II	P313 7900
6	Top link , cpl.	P313 7897
7	Drawbar, Cat. I Drawbar, Cat. II	P461 7911 P461 7915
8	Clamp	P461 9871

Table 4

Stand

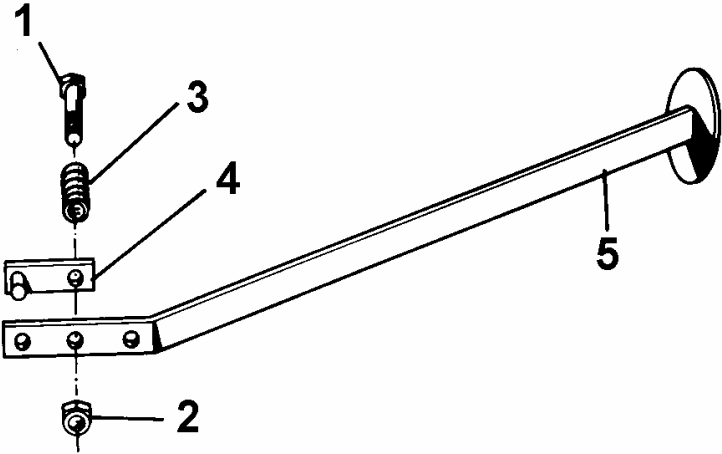

Pos. No.	Description	Reference
1	Bolt	P301 3977
2	Selflocking nut	P303 0935
3	Spring	P329 8130
4	Holder	P429 2483
5	Stand	P429 4366

Table 5

Basic frame

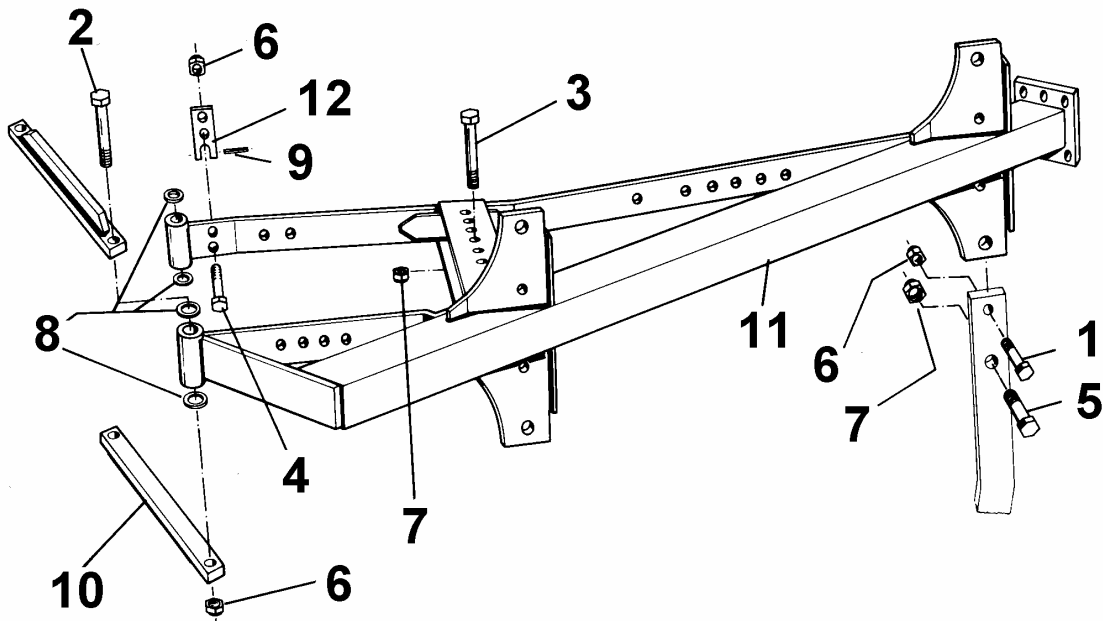

Pos. No.	Description	Reference
1	Shear bolt	P301 3838
2	Bolt	P301 4099
3	Bolt	P301 4478
4	Bolt	P301 5385
5	Bolt	P301 5390
6	Selflocking nut	P303 0935
7	Selflocking nut	P303 0936
8	Washer	P305 6148
9	Expansion pin	P309 6073
10	Bar	P402 2096
11	Basic frame	P402 6438
12	Lug	P434 1647

Table 6

Frame extension

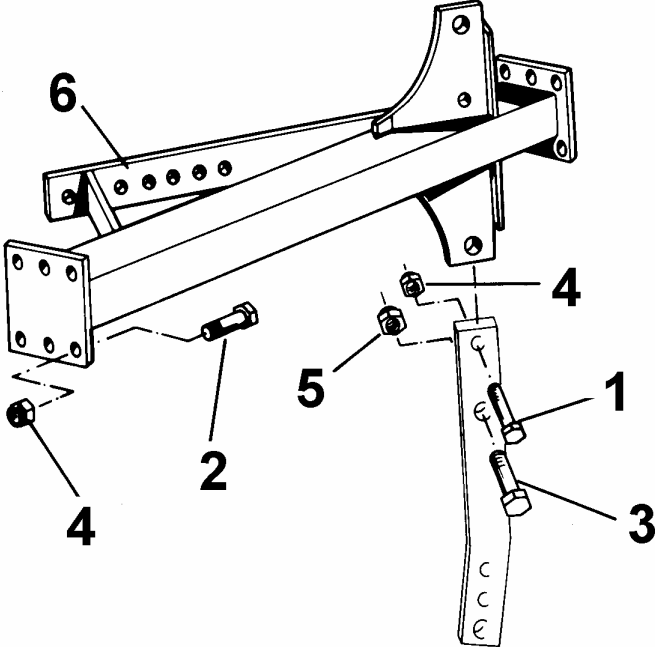

Pos. No.	Description	Reference
1	Shear bolt	P301 3838
2	Bolt	P301 5389
3	Bolt	P301 5390
4	Selflocking nut	P303 0935
5	Selflocking nut	P303 0936
6	Frame extension	P402 6421

Table 7

Legs and bolts

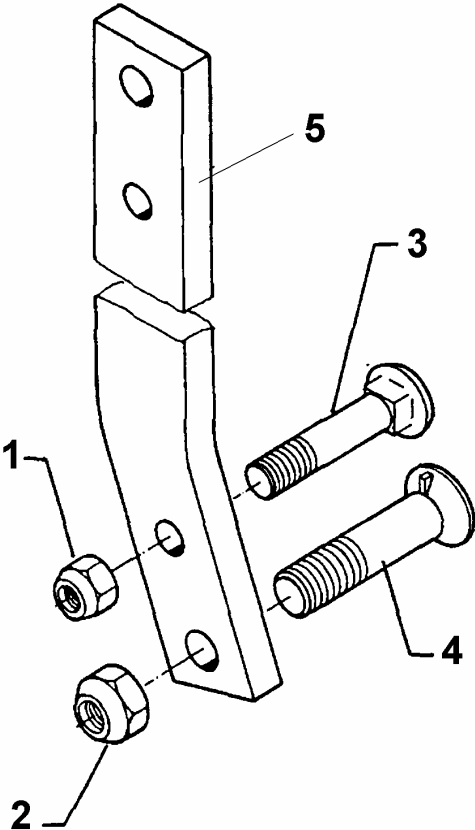

Pos. No.	Description	Reference
1	Selflocking nut	P303 0935
2	Selflocking nut	P303 0936
3	Bolt, cup square head (65 mm) Bolt, cup square head (70 mm)	P301 2242 P301 2261
4	CSK-Bolt (70 mm) CSK-Bolt (80 mm)	P301 5747 P301 5750
5	Leg – 60 cm underframe clearance Leg – 65 cm underframe clearance Leg – 70 cm underframe clearance	P464 3542 P464 3544 P464 3546

Table 8

Skim stalk

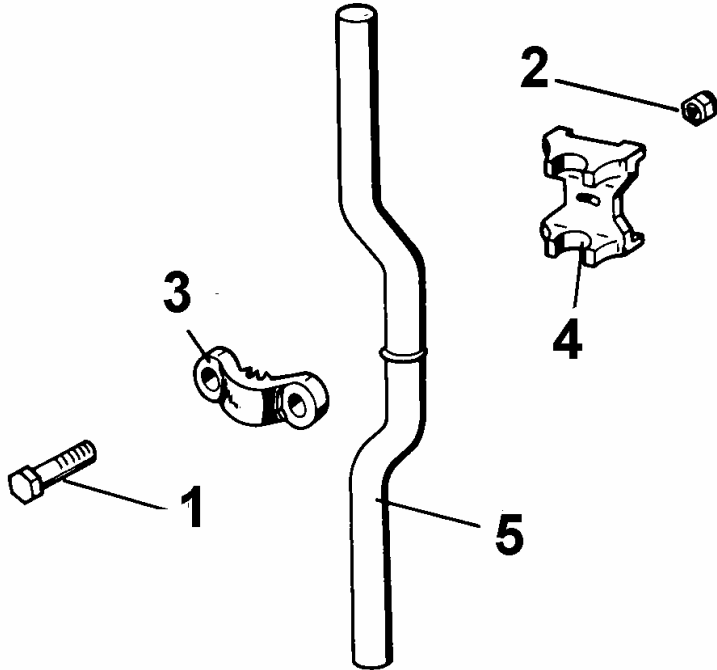

Pos. No.	Description	Reference
1	Bolt	P301 4369
2	Selflocking nut	P303 0936
3	Clamp	P459 9009
4	Clamping plate	P459 9013
5	Skim stalk	P463 8562

Table 9

Skimmer No. 1

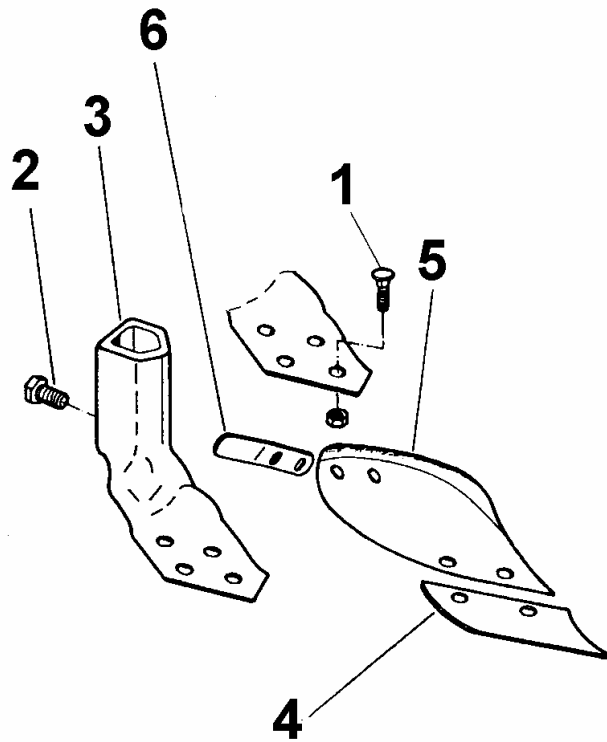

Pos. No.	Description	Reference
1	CSK – bolt with nut	P301 5771
2	Bolt with cutting ring	P301 3666
3	Frog, rh Frog, lh	P457 0820 P457 0821
4	Share, 190 mm, rh Share, 190 mm, lh	P336 3720 P336 3721
5	Mouldboard, rh Mouldboard, lh	P347 0650 P347 0651
6	Tail piece	P347 3650

Table 10

Universal body No. 35

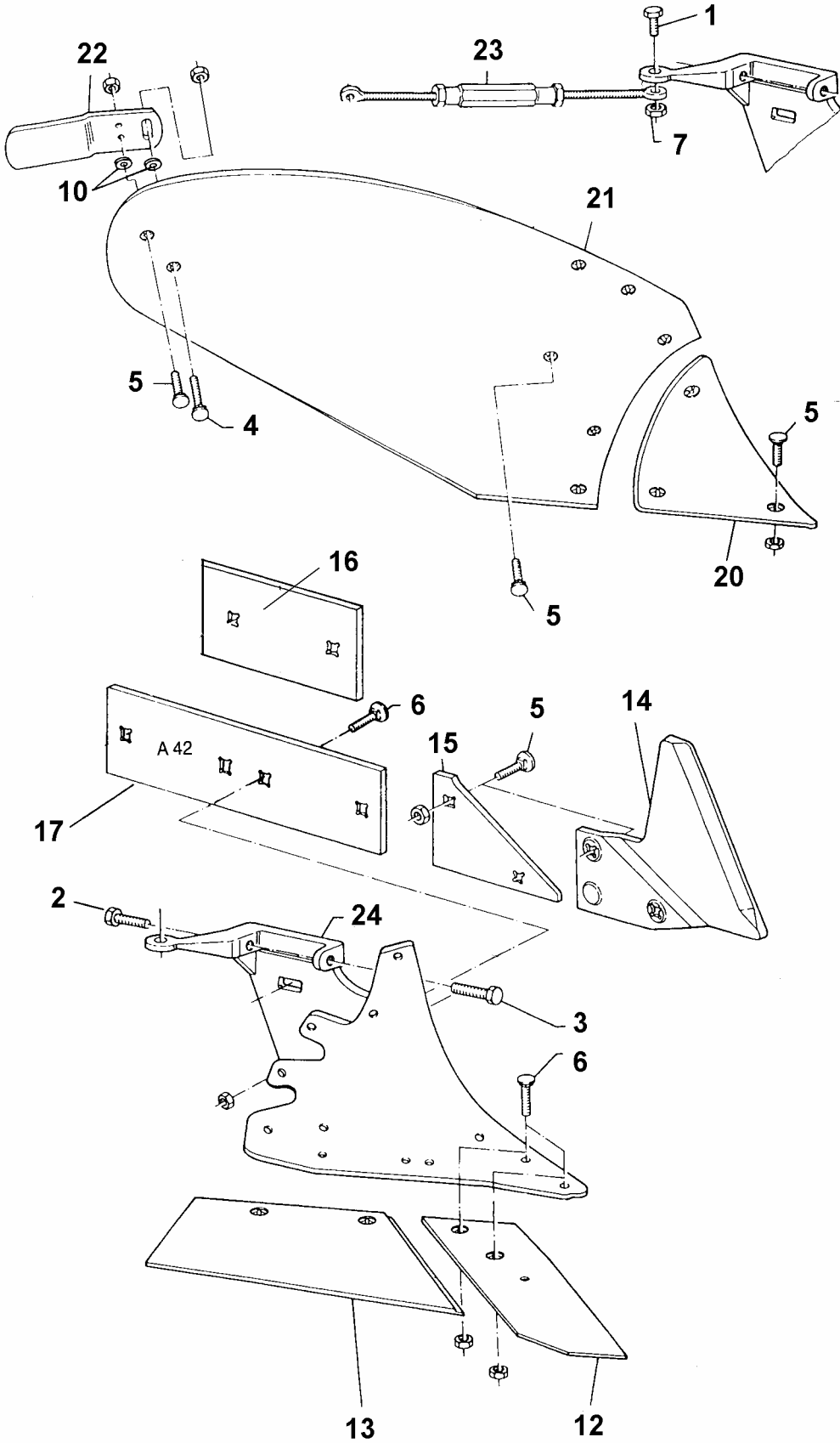

Universal body No. 35

Pos. No.	Description	Reference
1	Bolt	P301 5388
2	Bolt	P301 3774
3	Bolt	P301 3719
4	CSK Bolt with nut	P301 5769
5	CSK Bolt with nut	P301 5767
6	CSK Bolt with nut	P301 5785
7	Nut	P303 0935
10	Washer	P305 6134
12	Point, rh Point, lh	P336 4050 P336 4051
13	Wing, rh Wing, lh	P335 2020 P335 2021
14	Sword coultter, rh Sword coultter, lh	P349 2890 P349 2891
15	Landslide wedge.rh Landslide wedge, lh	P340 1900 P340 1901
16	Landside, short	P341 1500.0
17	Landside, long	P341 1504
20	Shin, rh Shin, lh	P345 1000 P345 1001
21	Mouldboard, rh Mouldboard, lh	P344 1034 P344 1035
22	Tail piece, rh Tail piece, lh	P347 6000 P347 6001
23	Mouldboard stay	P567 0172.0
24	Frog, rh Frog, lh	P467 1000 P467 1001

Table 11

Adjuster screw complete

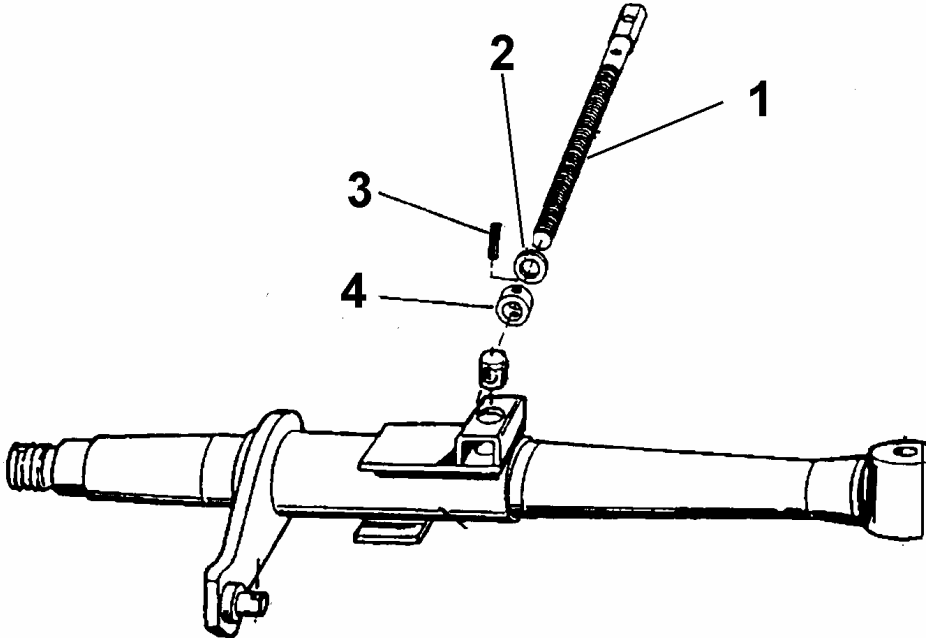

Pos. No.	Description	Reference
1	Adjuster screw	P302 7925
2	Washer	P305 6164
3	Expansion pin	P309 6070
4	Ring	P317 6897